

Quick Start Guide

SpeedPalm-V5L

Version: 1.0

Overview

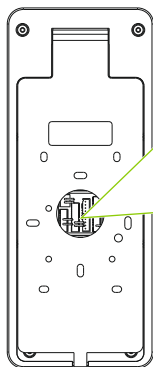
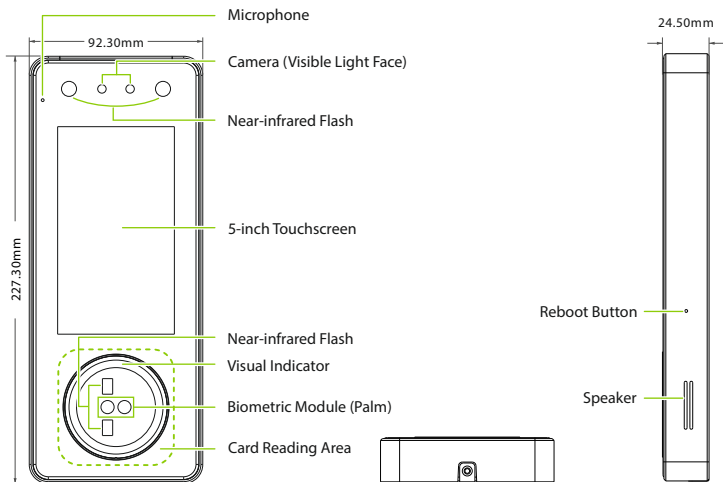

12V
GND

Power In

+12V
GND

IWD0

IWD1

WD0

WD1

Wiegand In

Wiegand Out

RXD2

TXD2

GND

RXD

TXD

GND

485A

485B

RS232

RS232

RS485

TX+

TX-

RX+

RX-

Ethernet

AUX

GND

SEN

GND

BUT

NO1

COM

NC1

AL+

AL-

Auxiliary Input

Sensor

Exit Button

Lock

Alarm

Installation Environment

Please refer to the following recommendations for installation.



INSTALL INDOORS ONLY



KEEP EFFECTIVE DISTANCE OF 0.3 to 2m



AVOID INSTALLATION NEAR GLASS WINDOWS



AVOID DIRECT SUNLIGHT AND EXPOSURE



AVOID USE OF ANY HEAT SOURCE NEAR THE DEVICE

Recommended Palm Gestures



Note:

1. Place your palm within **5 to 15 cm** of the device.
2. Place your palm in front of the biometric module, such that the palm is placed parallel to the device.
3. Make sure to keep space between your fingers.

Recommended Standing Posture and Facial Expression

Please keep your facial expression and standing posture natural while enrolment or verification.



Standalone Installation

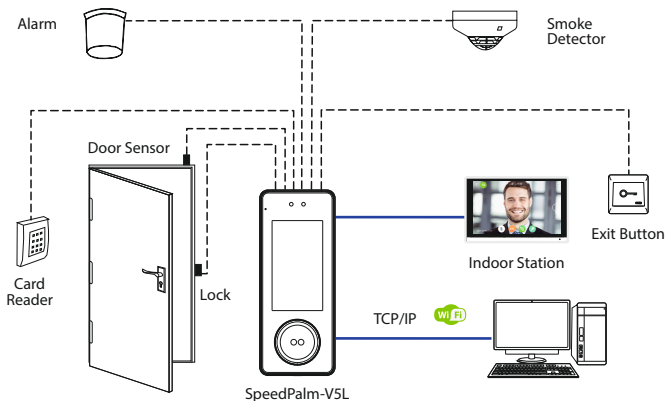

Power Connection

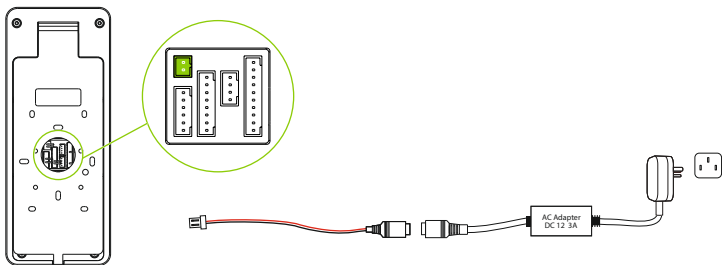

Recommended power supply

1. $12V \pm 10\%$, at least 3,000mA.
2. To share the power with other devices, use a power supply with higher current ratings.

Ethernet Connection

Connect the device and computer software over an Ethernet cable. As shown in the example below:

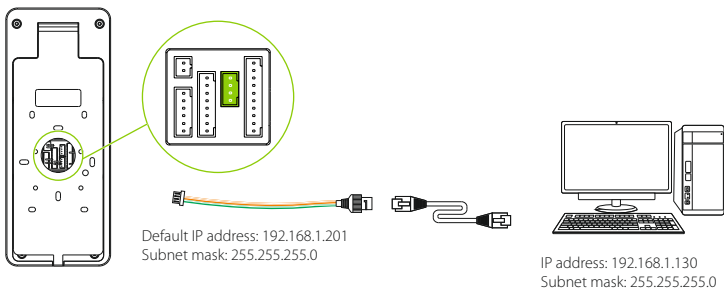

Click on **[COMM.]** > **[Ethernet]** > **[IP Address]**, input the IP address and click on **[OK]**.

Note: In LAN, the IP addresses of the server (PC) and the device must be in the same network segment when connecting to the **ZKBio CVAccess/ZKBio Time /ZKBio CVSecurity** software.

Wiegand Connection

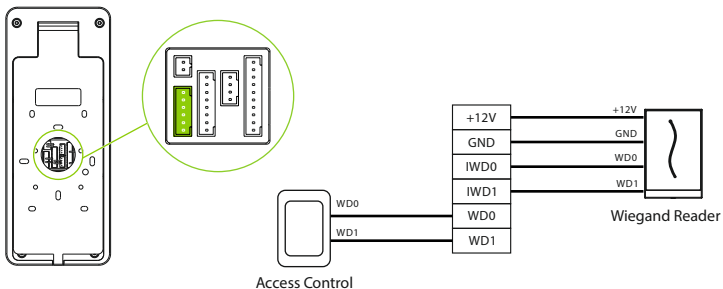

RS485 and RS232 Connection ★

The RS485 and the RS232 lets user connect to multiple readers to the device. The RS232 and RS485 can be connected to the terminal, as shown in the figure below.

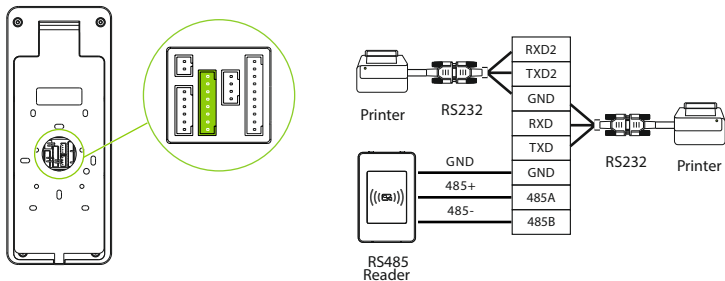

Note: Not all products have the function with ★, the real product shall prevail.

Door Sensor, Exit Button & Auxiliary Connection

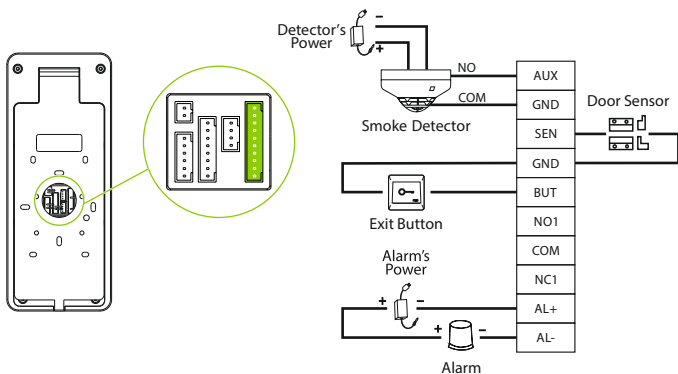

Lock Relay Connection

The system supports both **Normally Opened Lock** and **Normally Closed Lock**. The **NO Lock** (normally opened when powered) is connected with '**NO1**' and '**COM**' terminals, and the **NC Lock** (normally closed when powered) is connected with '**NC1**' and '**COM**' terminals. The power can be shared with the lock or can be used separately for the lock, as shown in the example with NC Lock below:

1) Device not sharing power with the lock

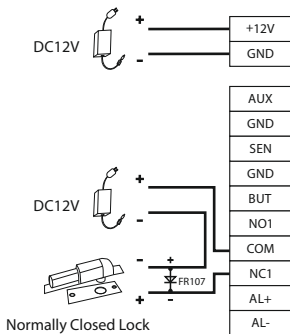

2) Device sharing power with the lock

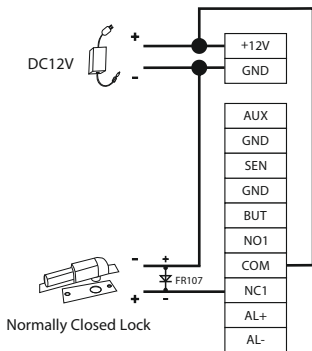

User Registration

When there is no super administrator set in the device, click on  to enter the menu. Add a new user and set User Role to Super Admin, then the system will request for the administrator's verification before entering the menu. It is recommended to register a super administrator initially for security purposes.

Method 1: Register on the Device

Click on  > **[User Mgt.]** > **[New User]** to register a new user. The options include entering the user ID and Name, setting User Role and Access Control Role, registering Face, Palm, Card, Password and Profile Photo.

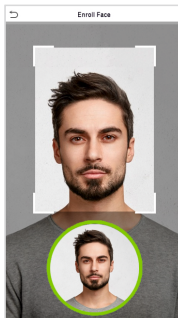
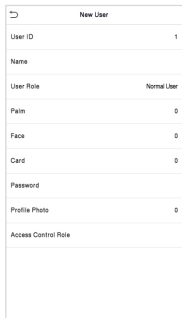
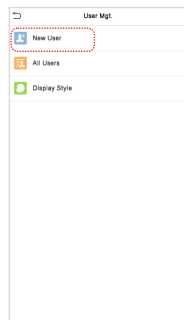
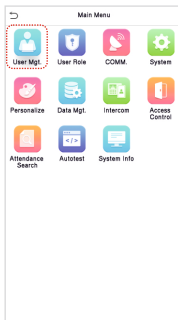
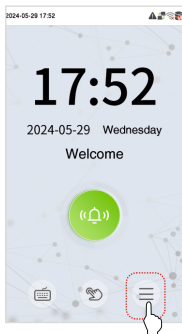

Method 2: Registering on ZKBio Time Software

● Register on the PC

Please set the IP address and cloud service server address on the device.

1. Click **[Device]** > **[Device]** > **[Add]** to add the device to the software. It can automatically be added when the device's server address and port are set.

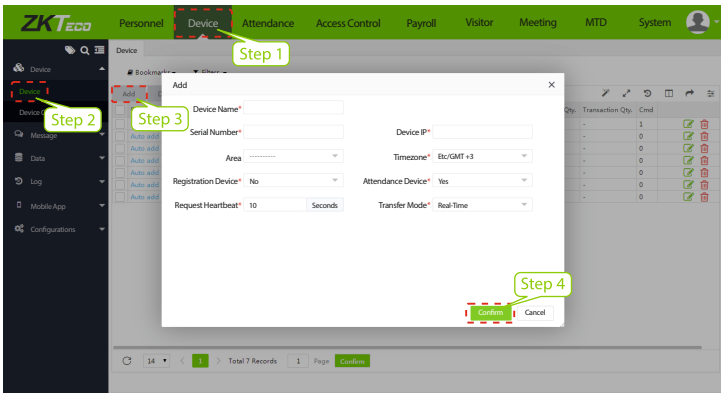

2. Click **[Personnel]** > **[Employee]** > **[Employee]** > **[Add]** to register users in the software.
3. Synchronize personnel on the software to the devices in the corresponding area.
4. In the personnel list, select an employee(s) and click **[More]** > **[Resynchronize to device]** to access the confirmation interface for synchronizing.

For more details, please refer to the *ZKBio Time User Manual*.

● Register on the Phone

Once the ZKBio Time software is installed, the users could enroll their face template via a browser application on their own mobile phone.

Click **[Device]** > **[Data]** > **[Bio-Photo]** > **[QR Code]** scan the QR code to enroll user's face template.

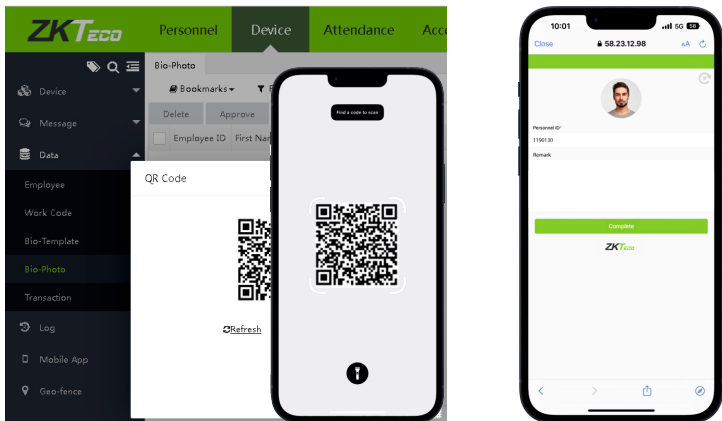

Note: Before registering a person's face, you need to register the information about the user on ZKBio Time software in advance. As, personnel ID, name and phone number, etc.

Method 3: Register on ZKBio CVAccess Software

● Register on the PC

Please set the IP address and cloud service server address in the Comm. Menu option on the device.

1. Click **[Attendance]** > **[Attendance Device]** > **[Authorized Device]** to search the device on the software. When an appropriate server address and port is set on the device, the searched devices are displayed automatically.

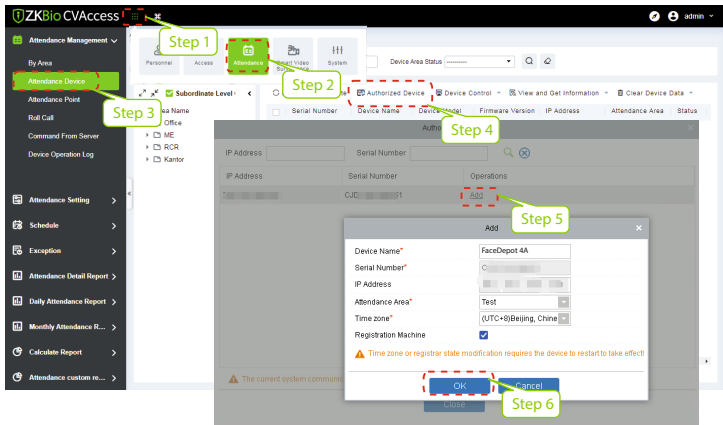

2. Click **[Add]** in operation column, a new window will pop-up. Select Icon type, Area, and Add to Level from each dropdowns and click **[OK]** to add the device.
3. Click **[Personnel]** > **[Person]** > **[New]** and fill in all the required fields to register a new users in the software.
4. Click **[Attendance]** > **[Attendance Device]** > **[Device Control]** > **[Synchronize Software Data to the Device]** to synchronize all the data to the device including the new users.

For more details, please refer to the *ZKBio CVAccess User Manual*.

● Register on the Phone

Once the ZKBio CVAccess software is installed, the users could enroll their face via a browser application on their own mobile phone.

1. Click **[Personnel]** > **[Parameters]**, input "http://Server address: Port" in the QR Code UGL bar. The software will automatically generate a QR code. Scan the QR code or login onto "http://Server address: Port/app/v1/adreg" by the mobile phone to register users.

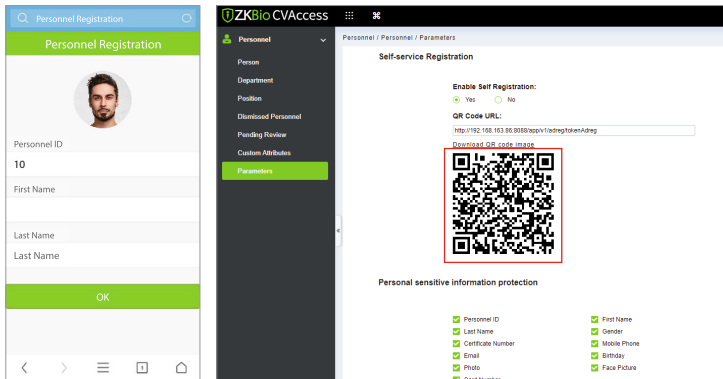

2. The users will be displayed in **[Personnel]** > **[Pending Review]**, click **[View]**.

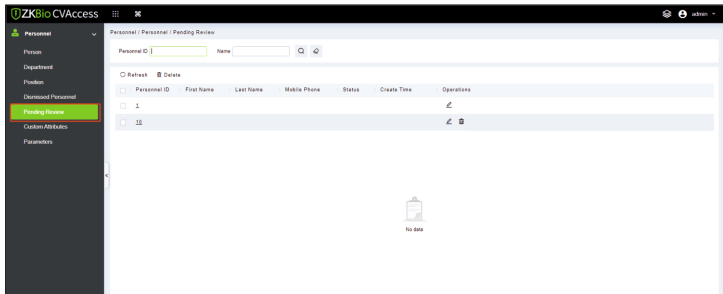

Method 4: Register on ZKBio CVSecurity Software

● Register on the PC

Please set the IP address and cloud service server address in the Comm. Menu option on the device.

1. Click **[Access]** > **[Access Device]** > **[Device]** > **[Search Device]** to search the device on the software. When an appropriate server address and port is set on the device, the searched devices are displayed automatically.

The screenshot displays the ZKBio CVSecurity software interface. The left sidebar shows the navigation menu with 'Access Device' selected. The main window shows the 'Device' tab with a search bar and a table of found devices. A search progress bar indicates 100% completion. A table lists two devices with their IP addresses, MAC addresses, and serial numbers. An 'Add' button is highlighted for the second device. A pop-up window titled 'Add' is shown, allowing the user to configure the device name, icon type, area, and add-to-level options. The 'OK' button in the pop-up is highlighted.

Step 1: Click **[Access]** > **[Access Device]** > **[Device]**

Step 2: Click **[Search Device]**

Step 3: Click **[Device]**

Step 4: Click **[Search]**

Step 5: Search progress bar shows 100% completion.

Step 6: Click **[Add]** in the operation column.

Step 7: Click **[OK]** in the Add dialog box.

2. Click **[Add]** in operation column, a new window will pop-up. Select Icon type, Area, and Add to Level from each dropdowns and click **[OK]** to add the device.
3. Click **[Personnel]** > **[Person]** > **[New]** and fill in all the required fields to register a new users in the software.
4. Click **[Access]** > **[Access Device]** > **[Device Control]** > **[Synchronize Software Data to the Device]** to synchronize all the data to the device including the new users.

For more details, please refer to the *ZKBio CVSecurity User Manual*.

● Register on the Phone

Once the ZKBio CVSecurity software is installed, the users could enroll their face template via a browser application on their own mobile phone.

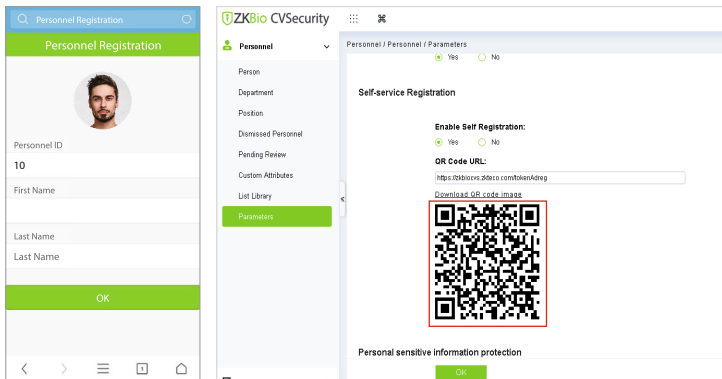

1. Click **[Personnel]** > **[Parameters]**, input “http://Server address: Port” in the QR Code UGL bar. The software will automatically generate a QR code. Scan the QR code or login onto “http://Server address: Port/app/v1/adreg” by the mobile phone to register users.



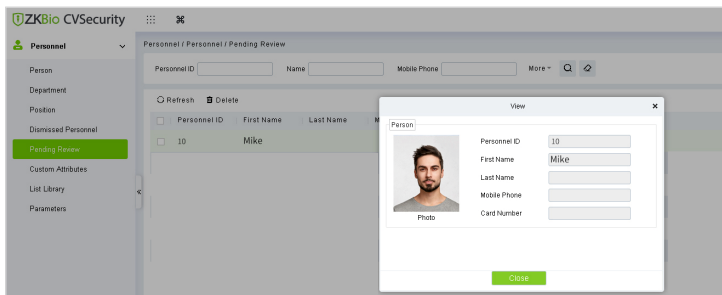

2. The users will be displayed in **[Personnel]** > **[Pending Review]**, click **[View]**.



Ethernet and Cloud Server Settings

Click on  > **[COMM.]** > **[Ethernet]** to set the network parameters. If the TCP/IP communication of the device is successful, the icon  will be displayed in the upper right corner of the standby interface.

Click on  > **[COMM.]** > **[Cloud Server Settings]** to set the server address and server port, that is, the IP address and port number of the server after the software is installed. If the device communicates with the server successfully, the icon  will be displayed in the upper right corner of the standby interface.

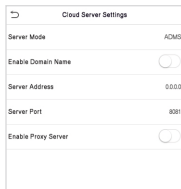
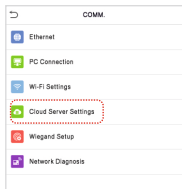
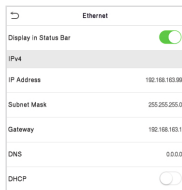
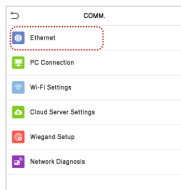
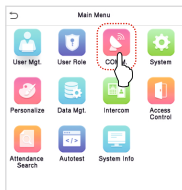

Access Control Setting

Click on  > **[Access Control]** to enter the access control management interface and set relevant parameters of access control.

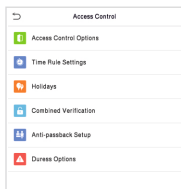
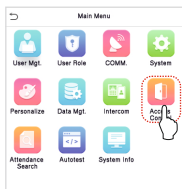

Health Protection

Click on ☰ > [System] > [Health Protection] to enable mask detection.

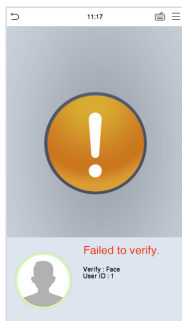
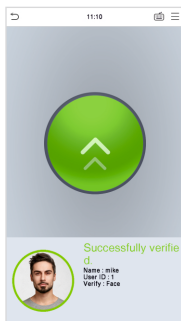
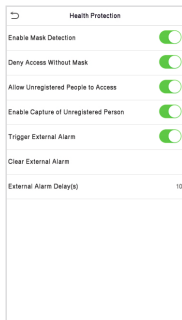
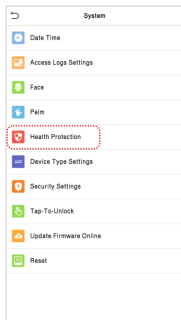
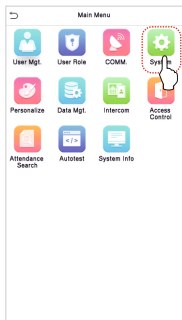

SIP Settings

This function needs to be used with the indoor station.

Local Area Network Use

1. Set the indoor station to the same network segment as the device.
2. Click on **[Intercom]** > **[SIP Settings]** > **[Advanced Settings]** > **[DTMF]** to set the value as same as the value of DTMF in the indoor station.
3. On the **SIP Settings** interface, enter **[Contact List]** > **[Add]** to add the connected indoor station.

Device Number: Customize the number of the indoor station.

Call Address: It is the IP Address of the indoor station.

● Enter the IP Address/Device Number of the Indoor Station

Click  icon on the standby page to enter the IP address/Device Number of the indoor station in the pop-up interface of the device.



SpeedPalm-V5L

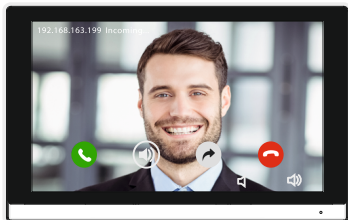

Indoor Station

● Calling by Shortcut

1. Click on ☰ > [Intercom] > [SIP Settings] > [Contact List].
2. Click **Add**, input device number and call address to add a new contact member.
Note: Call address and the SpeedPalm-V5L device must be in the same network segment.
3. Click [SIP Settings] > [Calling Shortcut Settings], select any item except admin, and enter the form information you just uploaded.
4. Then you can enter the device number or click shortcut key in the call screen to directly implement the video intercom.



SpeedPalm-V5L

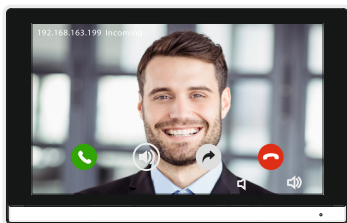

Indoor Station

● Direct Calling Mode

1. Click on ☰ > [Intercom] > [SIP Settings] > [Contact List].
2. Click **Add**, input device number and call address to add a new contact member.
Note: Call address and the SpeedPalm-V5L device must be in the same network segment.
3. Click [SIP Settings] > [Calling Shortcut Settings] > [Call Mode] > [Direct Calling Mode] > [Add]. Select the IP addresses of the indoor stations that you want to call, then the indoor stations will be displayed in the list.
4. Then you can tap the  icon on the device to call the indoor stations at the same time.



SpeedPalm-V5L

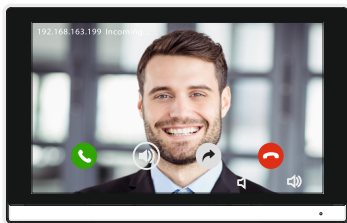

Indoor Station

SIP Server

1. Click on ☰ > **[Intercom]** > **[SIP Settings]** > **[Local Settings]** to activate the SIP server, and set the SIP server parameters.
2. Once the SIP is set up correctly, a green dot will appear in the upper right corner of the call page to indicate that the SpeedPalm-V5L device is connected to the server. You can call the account name of the indoor station.



SpeedPalm-V5L

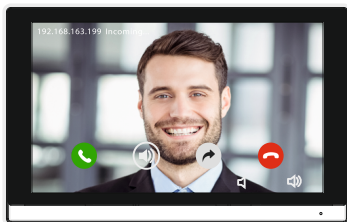

Indoor Station

Note: Users must obtain the server address and password from the distributor or build the server themselves if they need to activate the SIP server.

ZKTeco Industrial Park, No. 32, Industrial Road,
Tangxia Town, Dongguan, China.

Phone : +86 769 - 82109991

Fax : +86 755 - 89602394

www.zkteco.com

